

Serial Attached SCSI Architecture

Marty Czekalski, Maxtor



Serial Attached SCSI

- **Serial Attached SCSI (SAS) is the next evolution of SCSI beyond Ultra320 SCSI**
- **SAS has been designed to be a device and near cabinet interface only, not a network interface**
- **Leverages an enhanced Serial ATA (SATA) PHY while adding support for a second port**
- **SAS utilizes features of Fibre Channel AND compatibility with SATA drives in a point-to-point, switched architecture**



Key Serial Attached SCSI Features

- **Up to *16k physical links per domain* in a switched, point-to-point configuration for scalable performance**
- **Scalability with wide ports and future speed increases**
- **Data frame based on FCP**
- **Includes *rate matching* to optimize device transfer speeds**
- **Worldwide name addressing**
- **Uses a *simplified protocol* that will minimize interoperability issues between controllers & drives**
- **Dual-port drives for high availability**

Serial Attached SCSI Topology

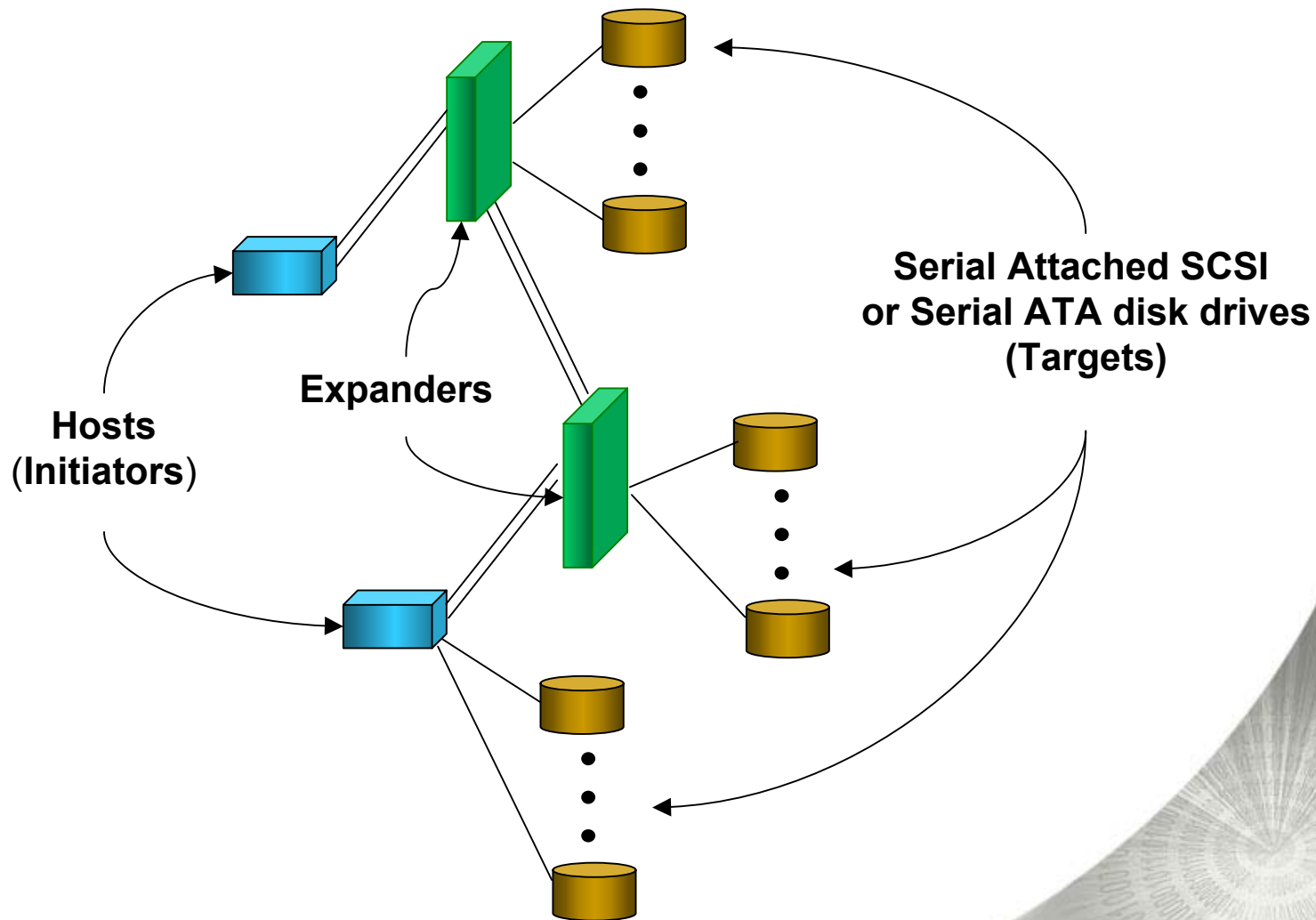

Multiple Pathways Allow Concurrent Operation

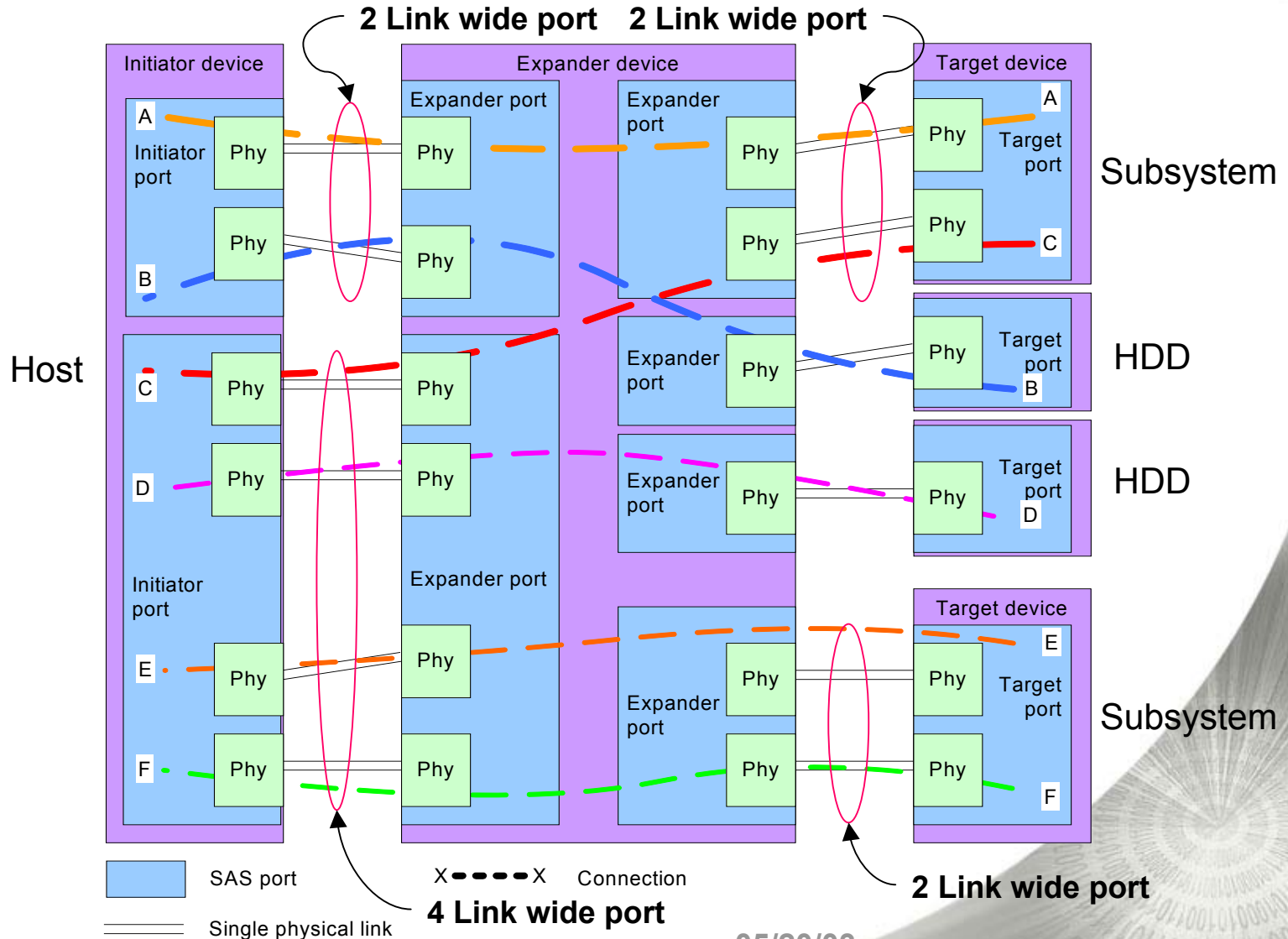

Maximum Expander Device Topology

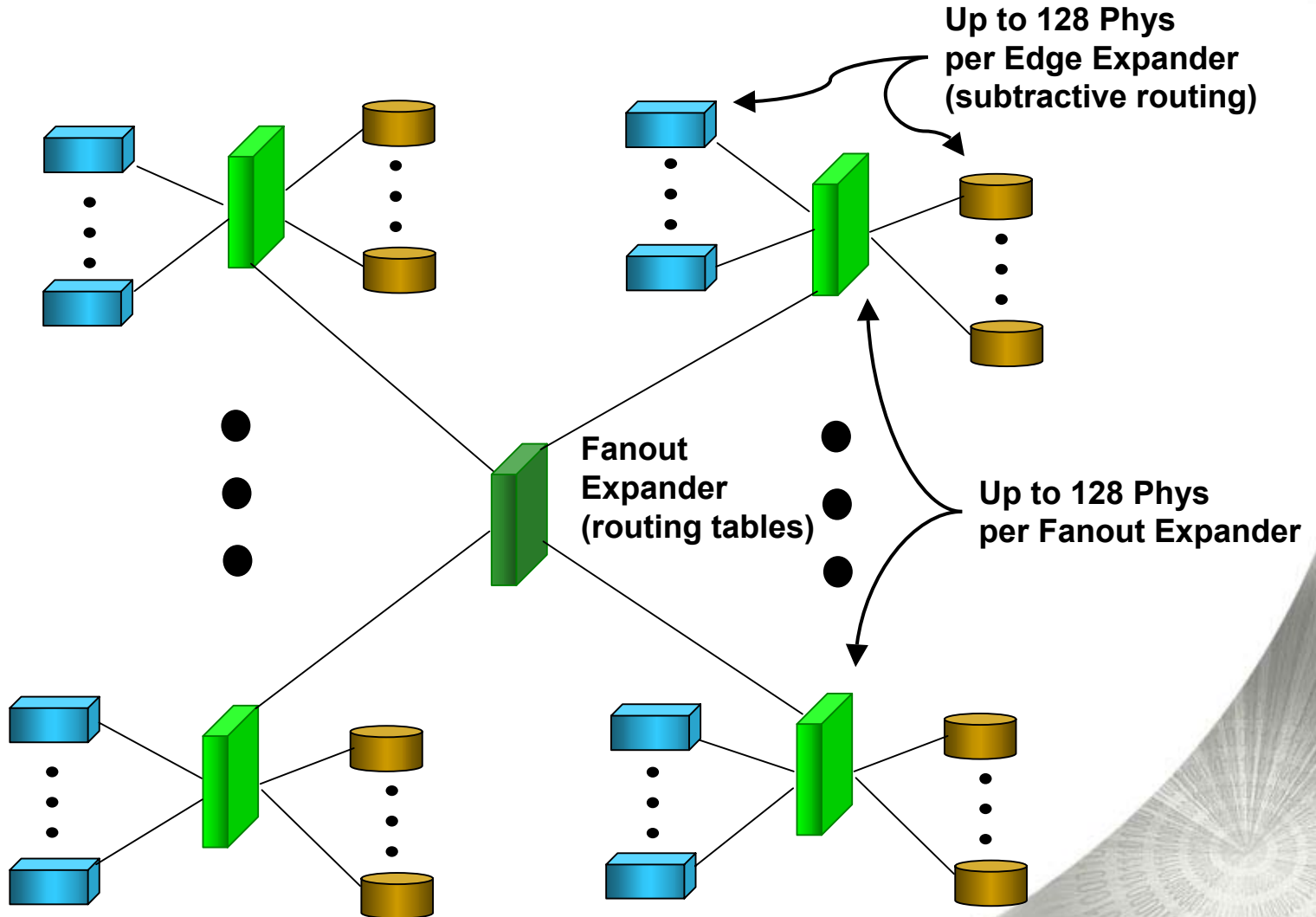

Two Edge Expanders

Up to 128 Phys
per Edge Expander

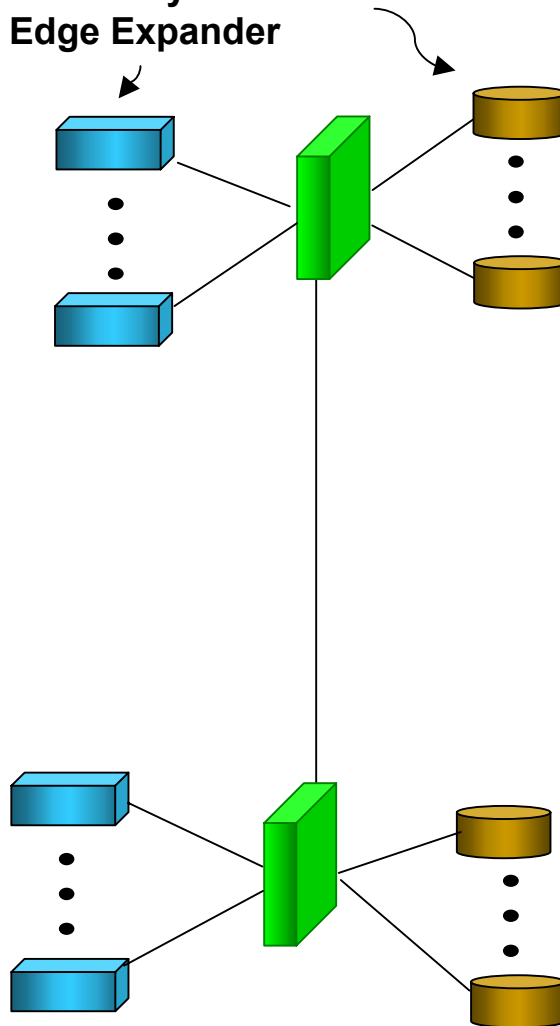

**A maximum of two
Edge Expanders can
be connected without
the use of a Fanout
Expander**

Typical Serial Attached SCSI Configuration

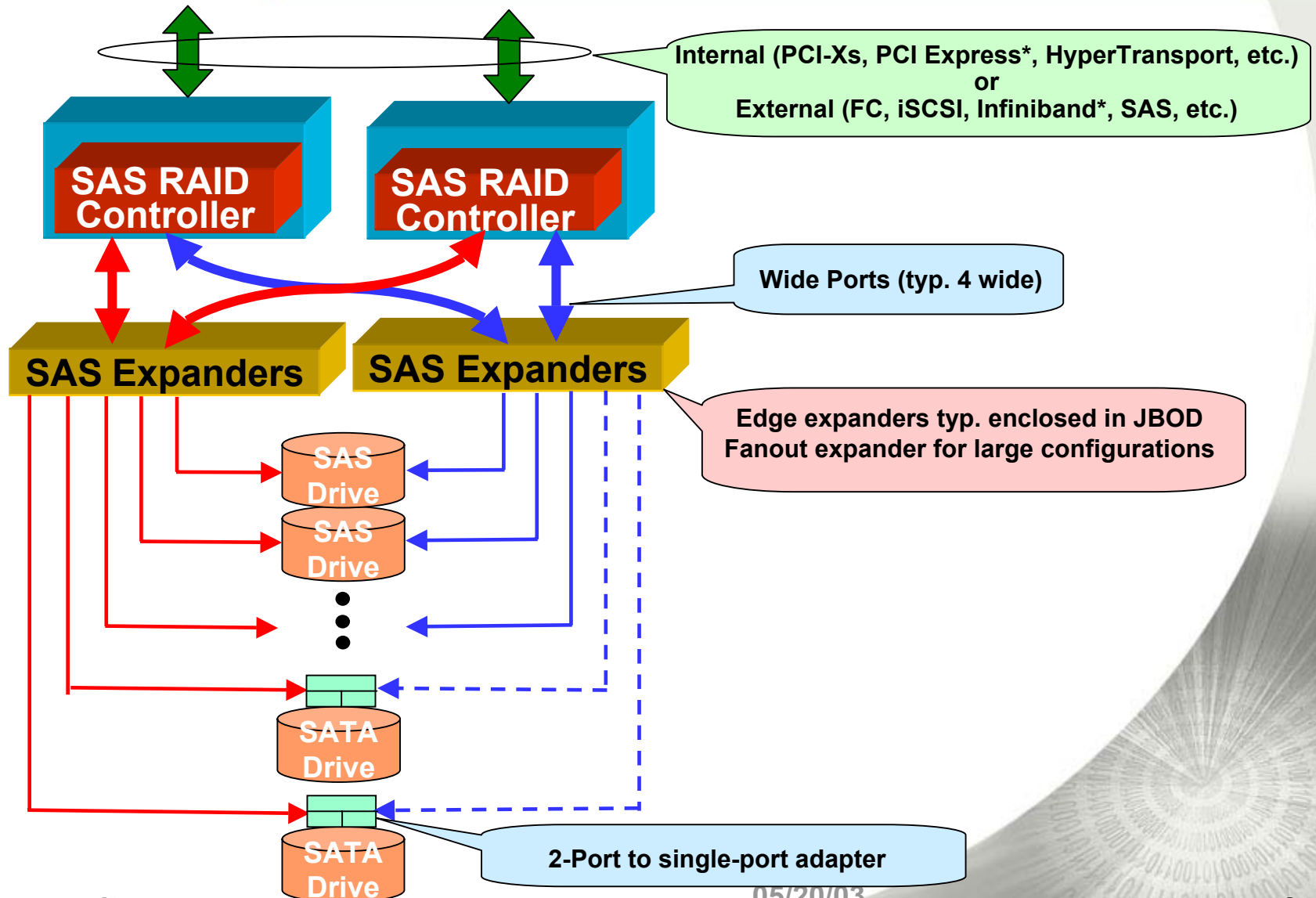

Out of Band Signaling (OOB)

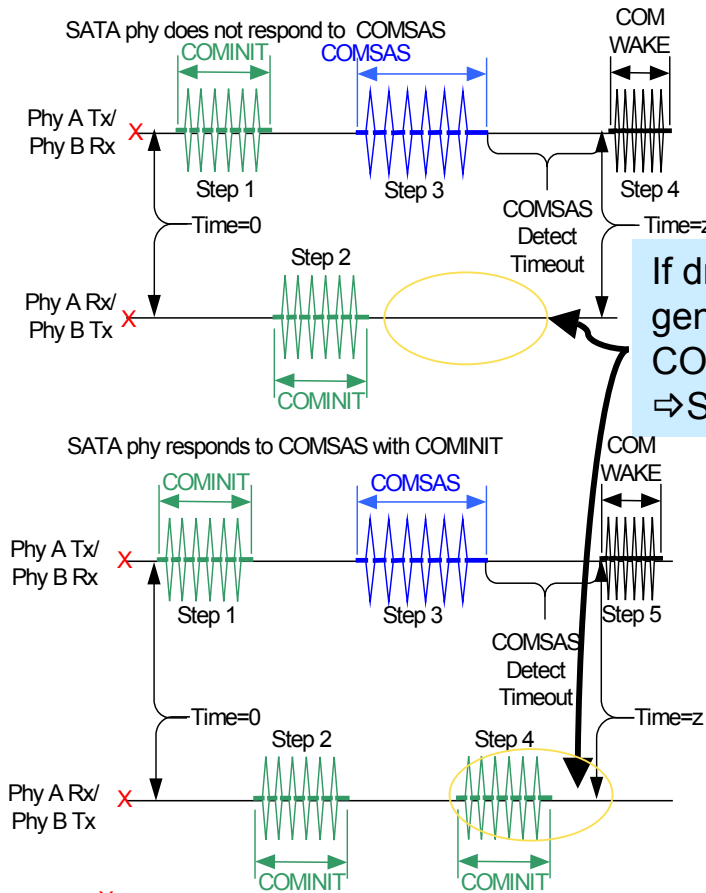

If drive does NOT generate a COMSAS burst ⇒ SATA Drive

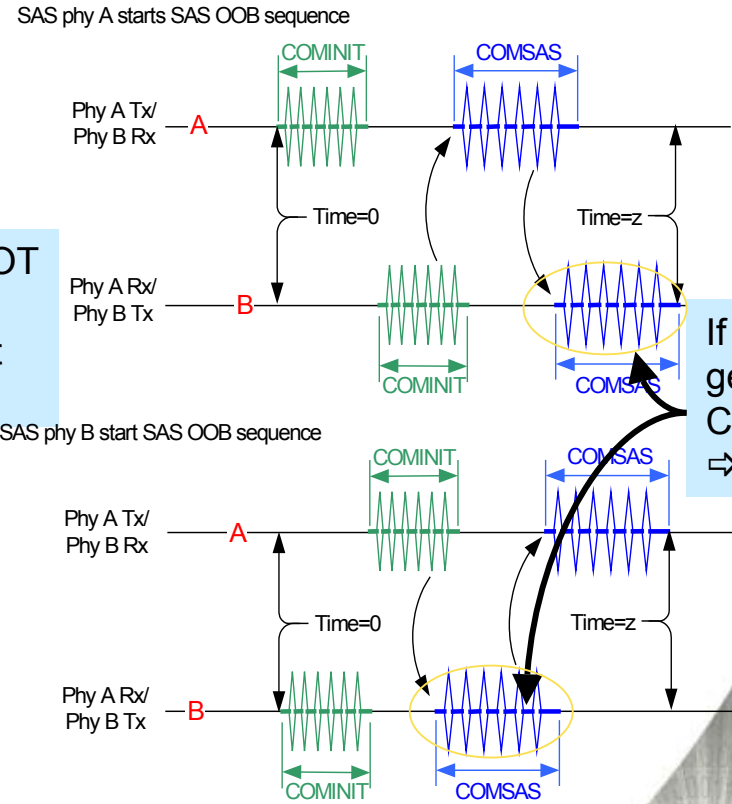

If drive generates COMSAS ⇒ SAS Drive

A : SAS A Power-on
 B : SAS B Power-on
 Time 0: SAS phy reset sequence begins

X : Power-on
 Time 0 : SAS phy reset sequence begins
 Time z : Post-COMRESET/COMINIT SAS-SATA reset sequence begins

Presence or absence of COMSAS OOB signal easily identifies a HDD as SATA or SAS

Serial Attached SCSI Expander Operation (with SAS drives)

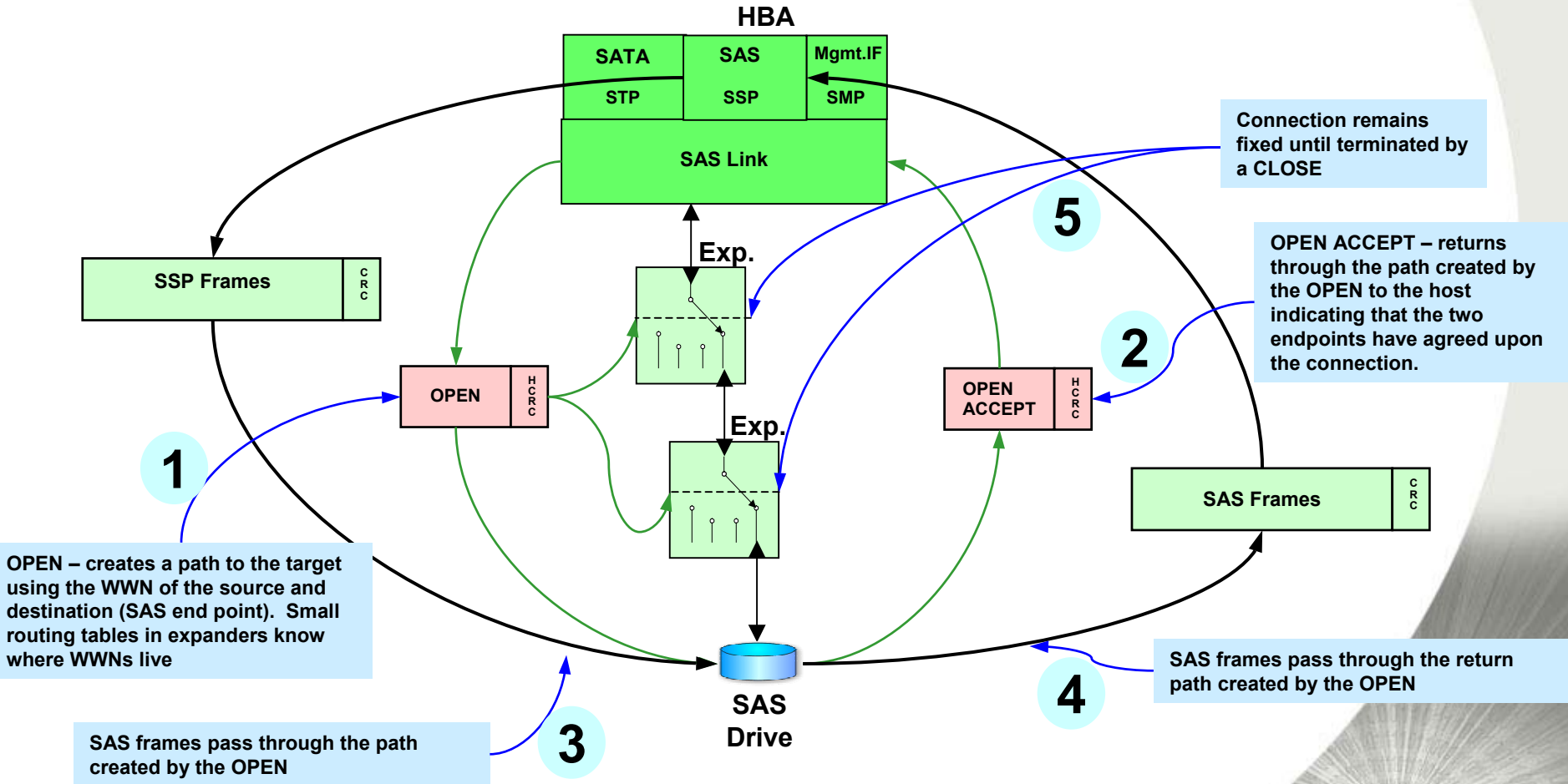

NOTE: SAS drive handle SSP and handle the OPEN process themselves directly using their own WWN

Serial Attached SCSI Expander Operation (with SATA drives)

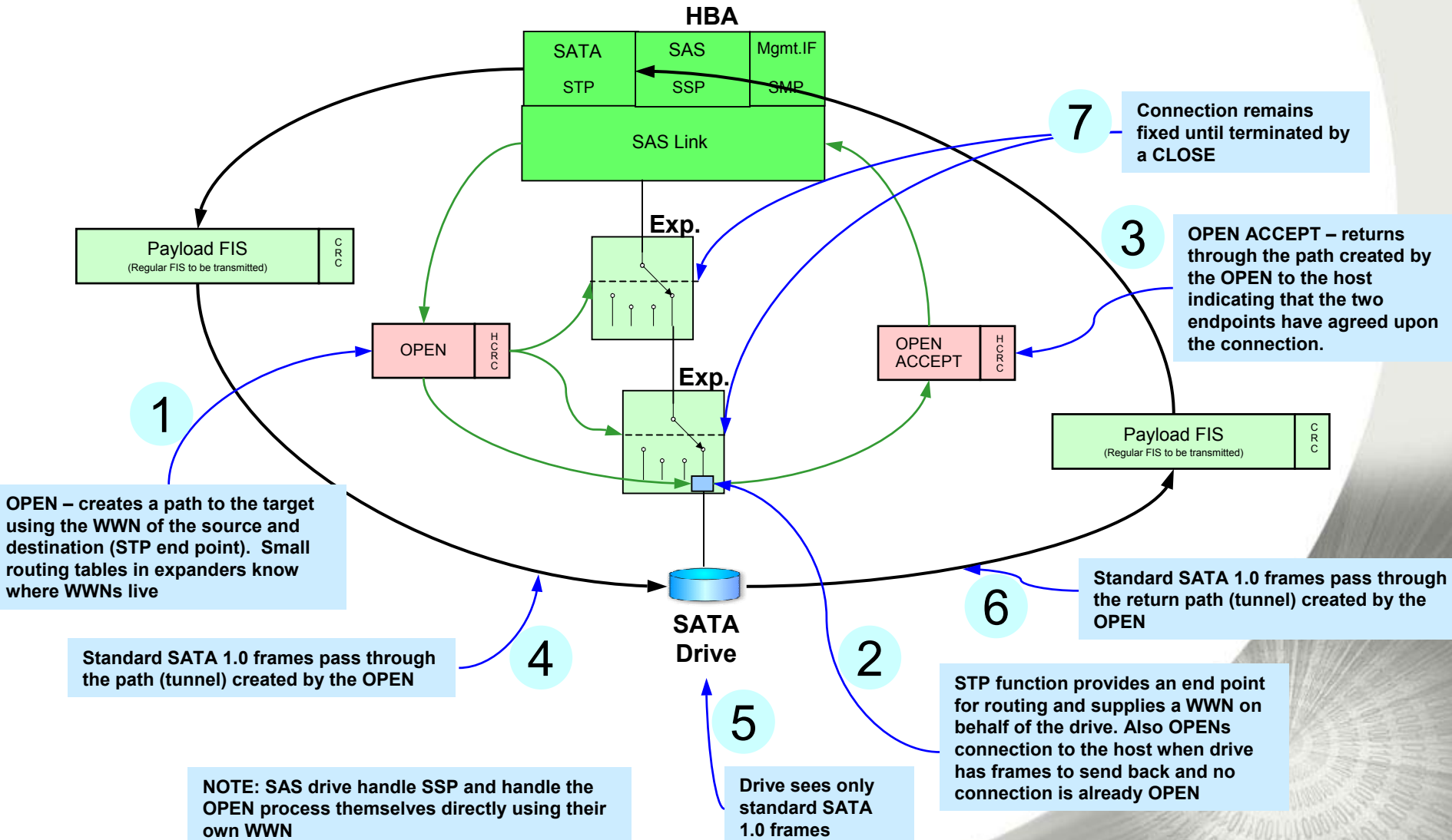

- Serial ATA II extensions are backward compatible with Serial ATA 1.0
- STP transports SATA FISes thru SAS domain
- SATA Command Queuing extensions transported in a FIS
 - **SAS doesn't care what's in the FIS**
- SATA command queuing drive required
- STP initiator port must support SATA command queuing

Enabling Future Compatibility

- Many of the same companies are in both groups
 - **Many of the same people are in both groups**
- Serial ATA 1.0 has transitioned to T13
- Serial ATA II has resolved legal issues that prevented sharing developing SATA technologies with T10
- SCSI Trade Association & SATA II Working Group publicly agree to work together:
 - **Marketing**
 - **Technical**